

HF2000A-UPF Series (RoHS 対応品)

単相2線式 250VAC

広帯域高減衰タイプ



UL1283 (file No.E102708)
EN60939-2 (file No.R50043691)

用途

IGBTインバータ、ACサーボ、NC制御機器など

仕様

Part No.	Rated Current	Weight	Dimensions [mm]														
			A	B	C	D	E	F	G	H	J	K	L	M	N		P
HF2005A-UPF	5A	0.3kg														fig1	
HF2010A-UPF	10A																
HF2015A-UPF	15A																
HF2020A-UPF	20A	0.6kg														fig2	
HF2030A-UPF	30A																
HF2040A-UPF	40A	1.5kg	197.5	180	(173.5)	164	147.5	86	70	22	60	41.2	R2.25 L6	dia.4.5	M5	—	fig3
HF2050A-UPF	50A	2.6kg	267.5	250	(243.5)	234	217.5	90	70	22	60	41.2	R3.25 L8	dia.6.5	M6	—	
HF2060A-UPF	60A																
HF2080A-UPF	80A	5kg	324.5	300	(297.5)	284	267.5	120	100	28.5	70	46.2	R3.25 L8	dia.6.5	M8	M6	fig4
HF2100A-UPF	100A																
HF2150A-UPF	150A	7kg	324.5	300	(297.5)	284	267.5	120	100	28.5	100	76.2	R3.25 L8	dia.6.5	M8	M6	fig5
HF2200A-UPF	200A	13kg															
Rated Voltage	250VAC max																
Leakage Current	1.2mA max / 250VAC 60Hz By UL1283																
Ambient temp.	-20 up to 50 Deg.C																

fig.1 (5, 10,15A)

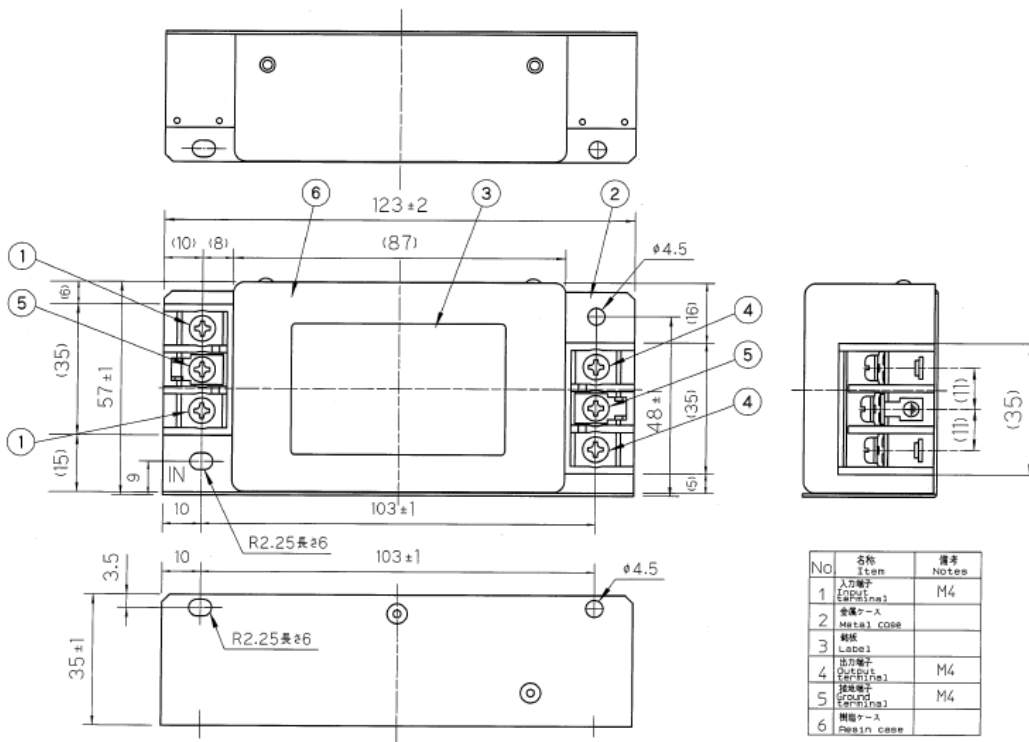

fig.2 (20, 30A)

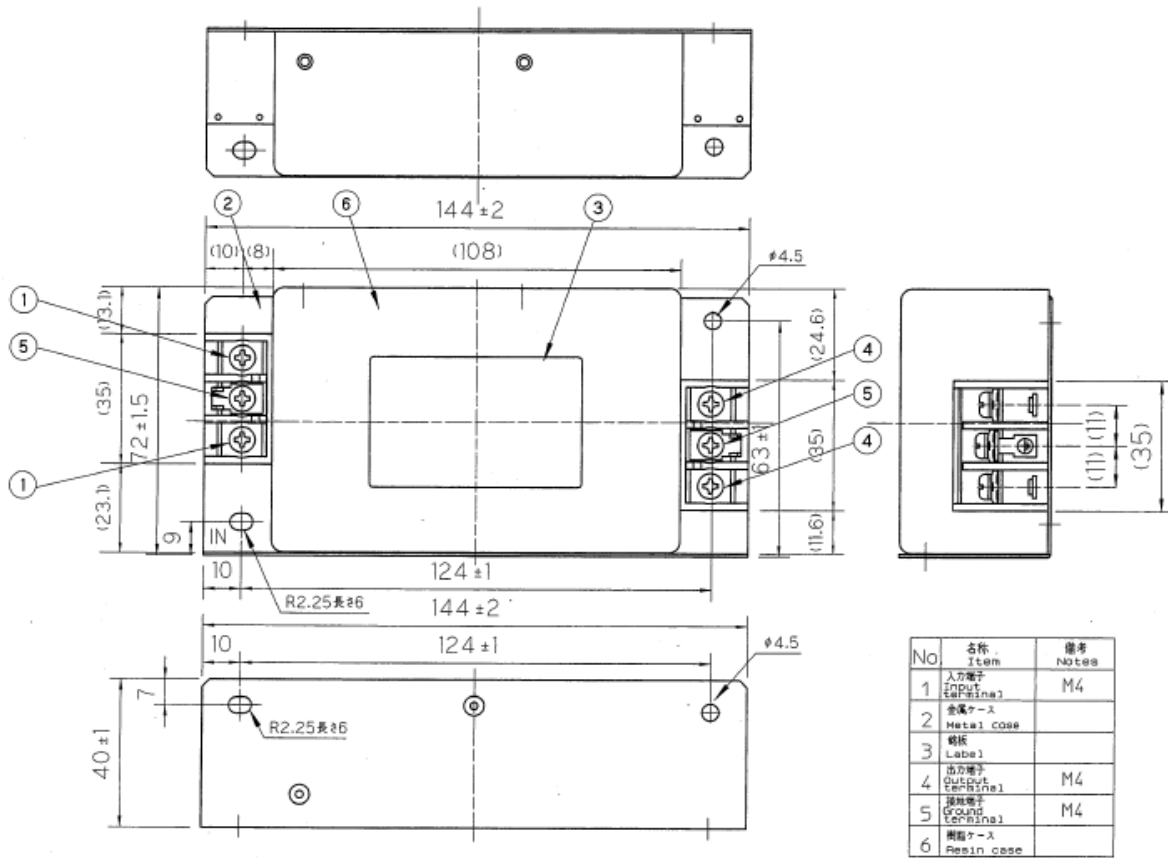

fig. 3 (40, 50, 60A)

- ・アース線は筐体取り付け穴を利用してください。
- ・端子台脇のネジは端子台固定ネジのため、はずさないでください。

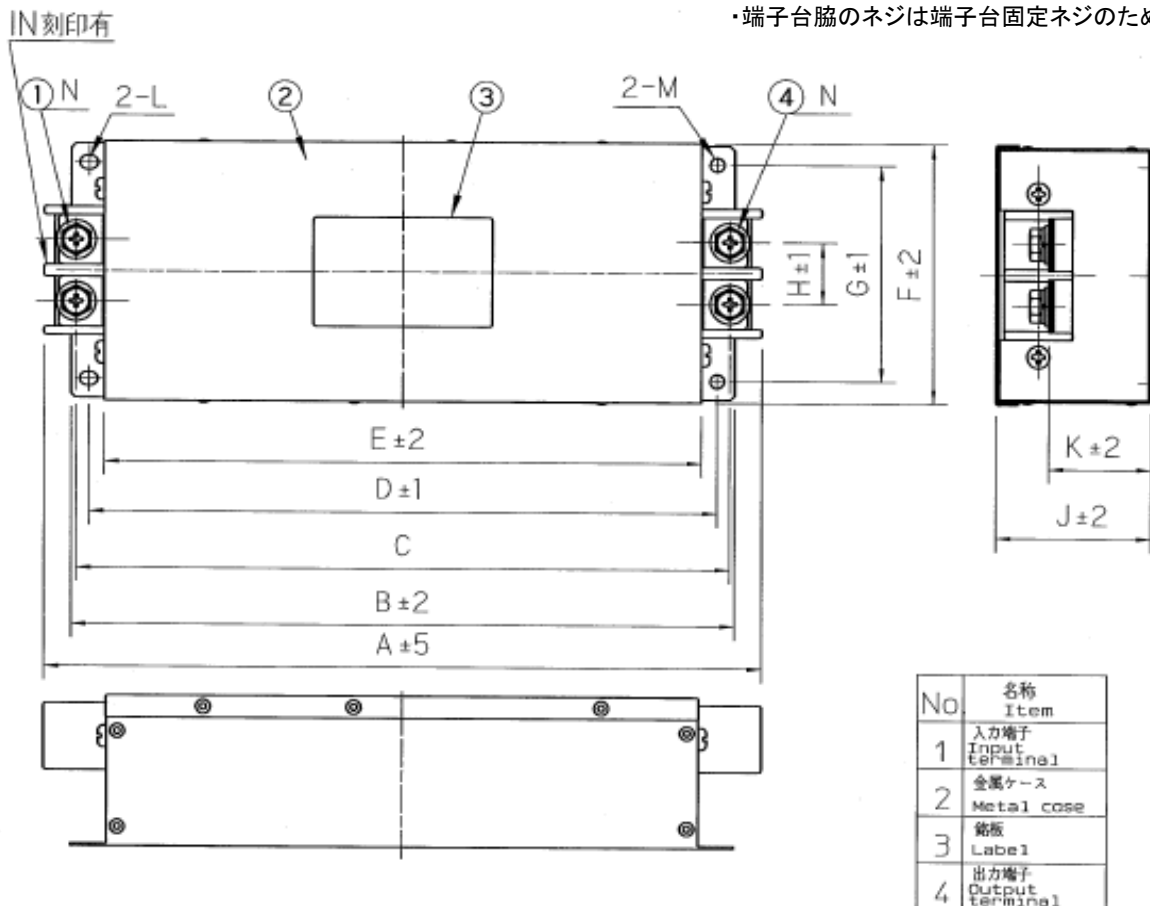

fig. 4 (80, 100, 150A)

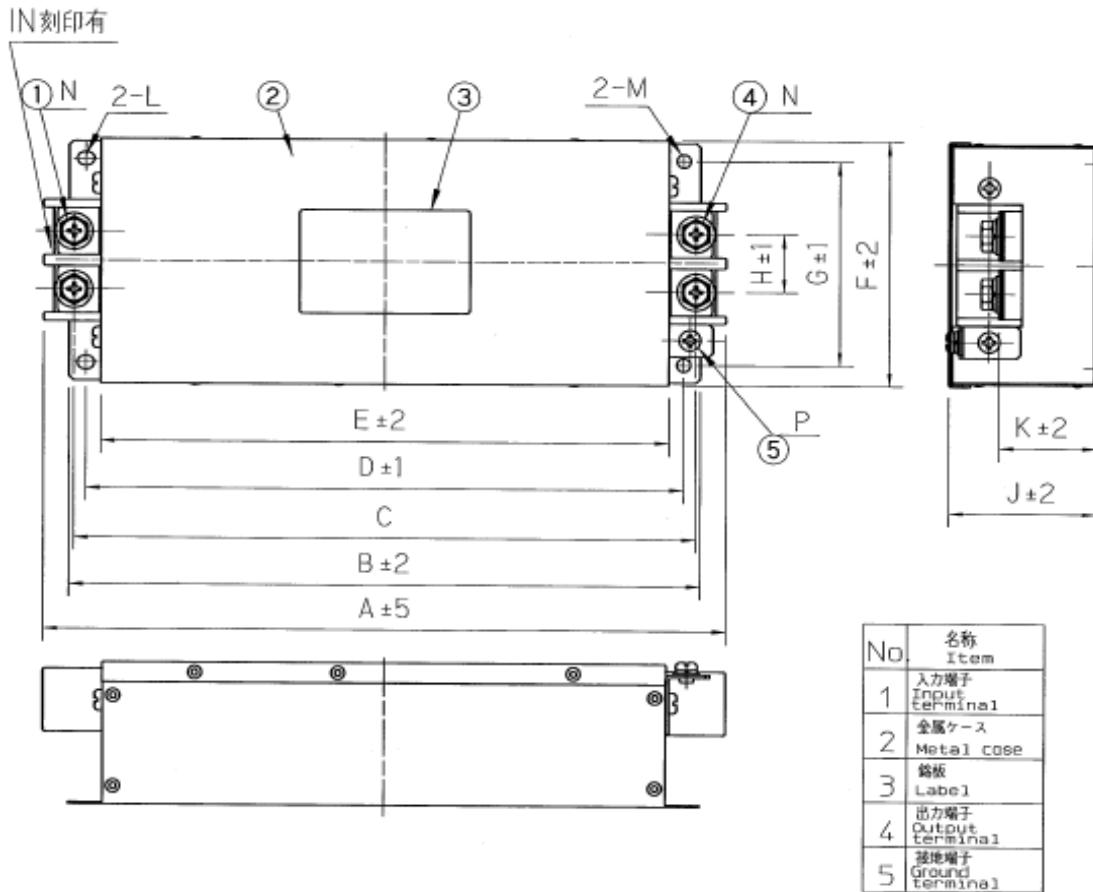
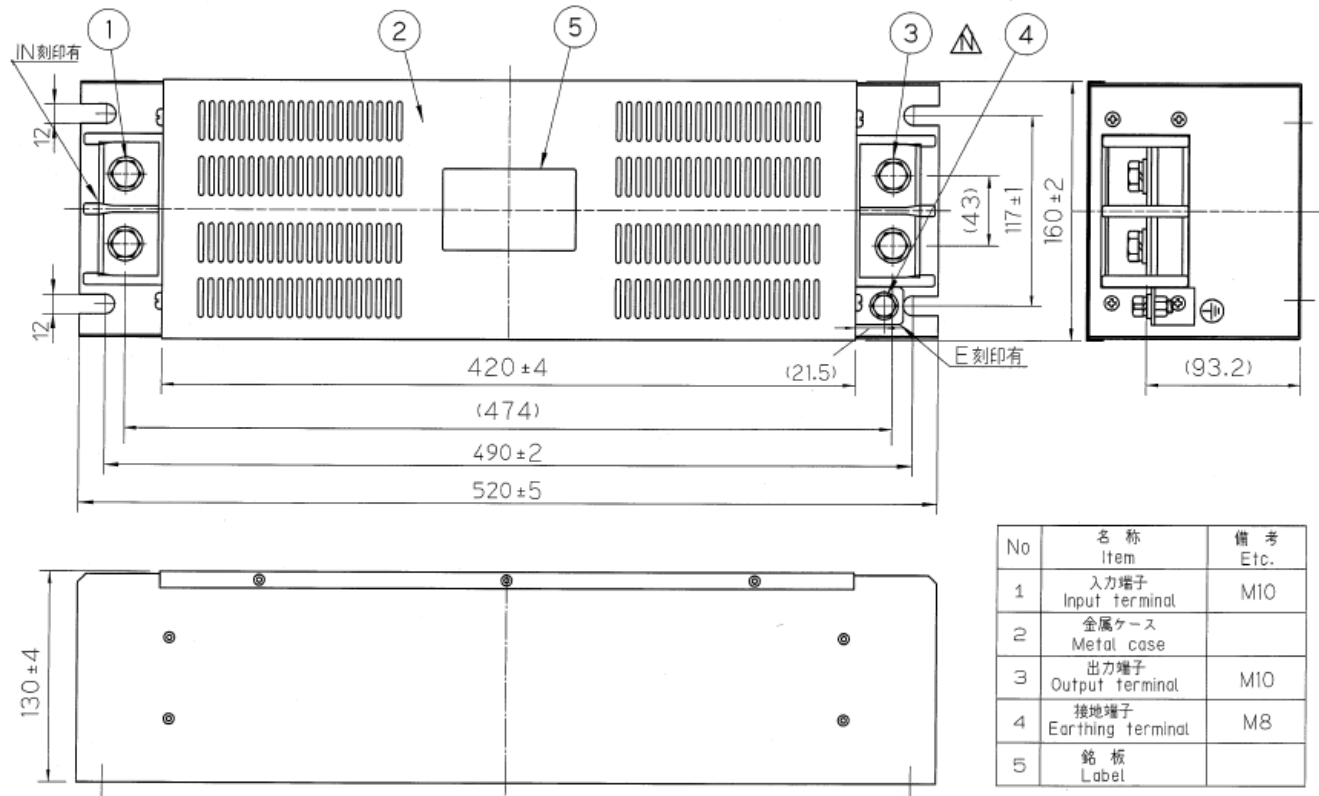
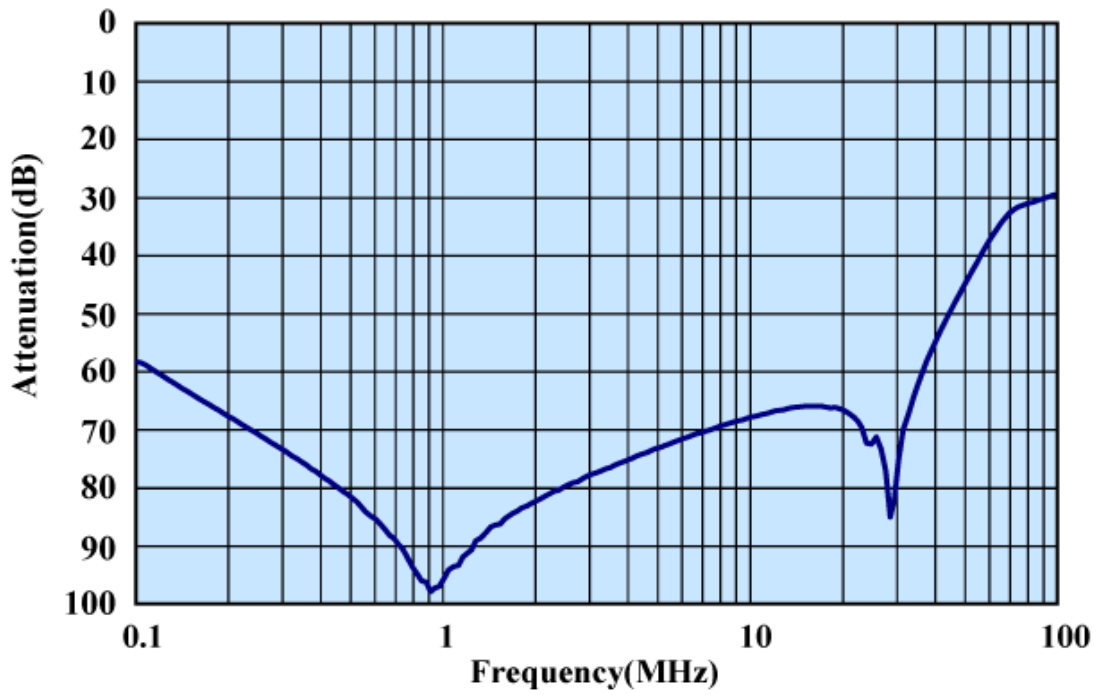

fig. 5 (200A)



代表特性 (20A)



代表特性 (100A)

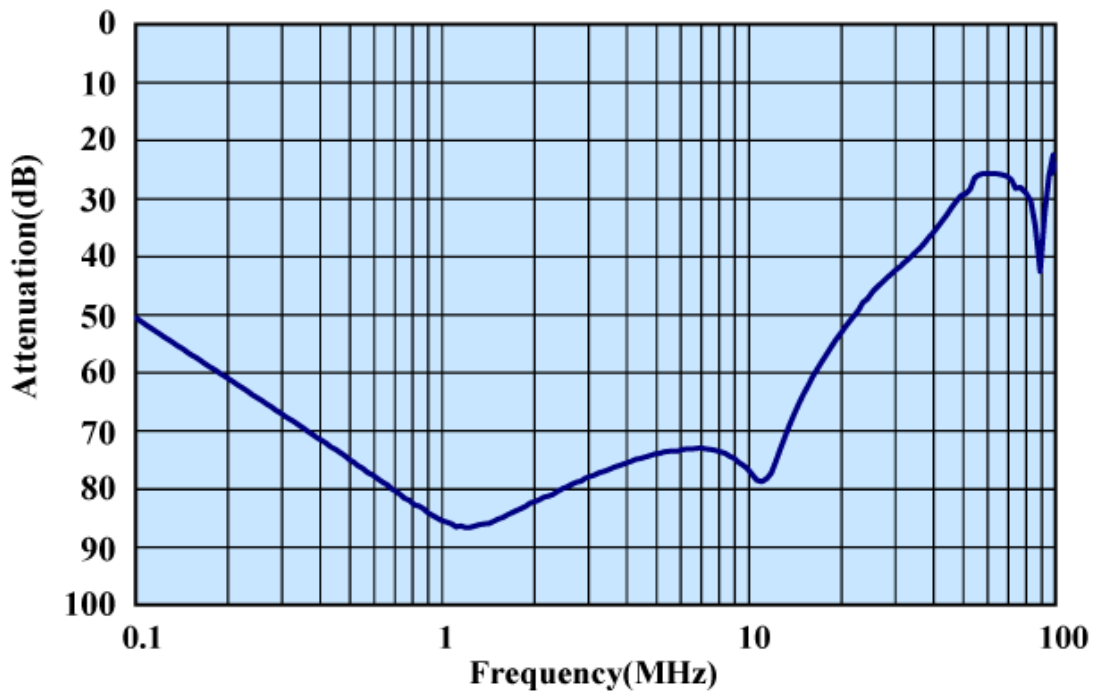

回路图

