

Product Information

Control No. : ARP-4616900-A 1

Issued on August 7, 2023

Measured Data

RoHS Compliant Part

1. Type No.

HMD6169B

2. Dimension (Unit : mm)

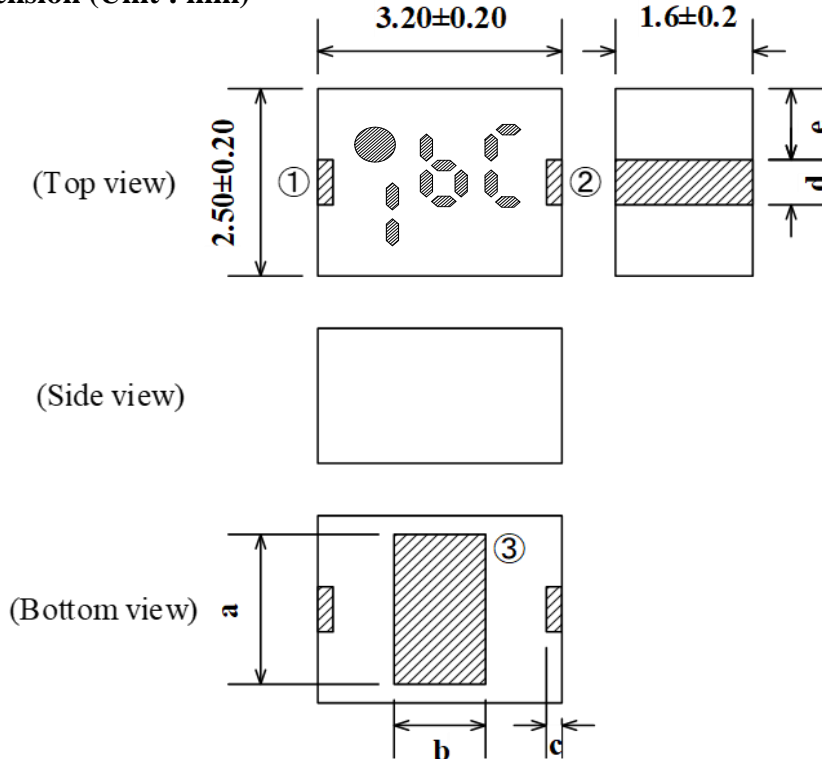

Terminal	
①	Input
②	Output
③	GND

Terminal Dimensions	
a	2.00 Typ.
b	1.20 Typ.
c	0.30±0.15
d	0.60±0.20
e	0.95 Typ.

3. Electrical characteristics

Parameters	Specification	Measured	Unit	Remark
Frequency range	2100 - 3000	-	MHz	
Nominal impedance	50	-	ohm	
Insertion Loss at 25degC.	2.0 Max.	1.25	ohm	
Ripple	1.5 Max.	0.64	dB	
Return Loss in BW	12 Min.	0.6	dB	
Attenuation	930 - 1740 MHz	20 Min.	38.6	dB
	4860 - 5700 MHz	30 Min.	62.0	dB
	6100 - 7000 MHz	20 Min.	54.1	dB
	8800 - 9700 MHz	20 Min.	45.7	dB
	10000 - 10900 MHz	15 Min.	39.2	dB

4. Note

- 4.1 Operating Temperature Range : -40 to +105 degC.
 4.2 Storage Temperature Range before soldering in taping package : -20 to +35 degC.
 4.3 Max Input Power : 1W Avg/CW
 4.4 Standard Reel Quantity : 2,000 pcs (per reel, per bag)

Approved by	Confirmed by	Raised by
Y. Imai	S. Suzuki	H. Aizawa

SOSHIN ELECTRIC CO., LTD

5. Representative characteristics

Measured Data

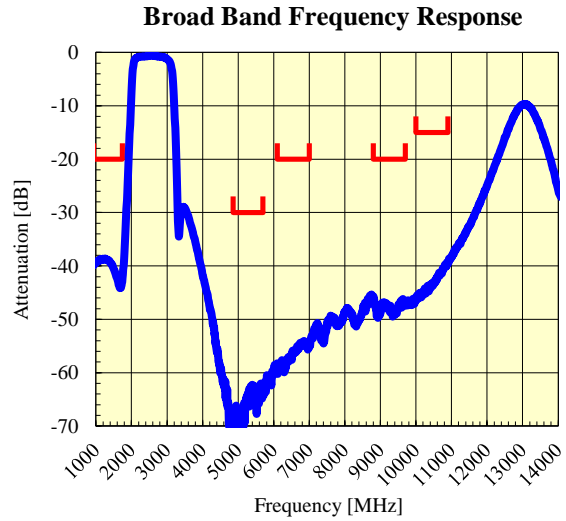
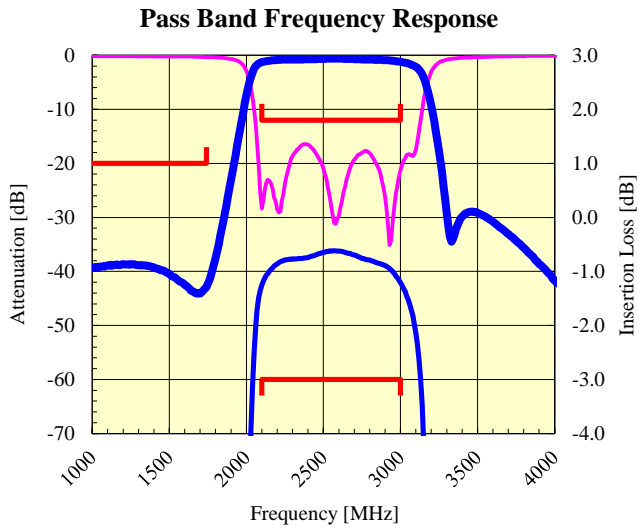

6. Recommended Land Pattern (Unit:mm)

*Land Pattern

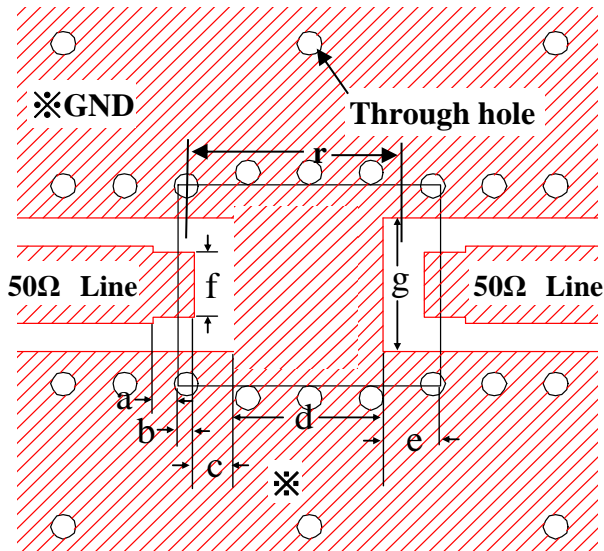

a	0.30 mm	e	0.45 - 0.80 mm
b	0.20 mm	f	0.80 mm
c	0.25 - 0.60 mm	g	1.66 mm
d	1.60 - 2.30 mm	r	2.80 mm

*Resist Pattern

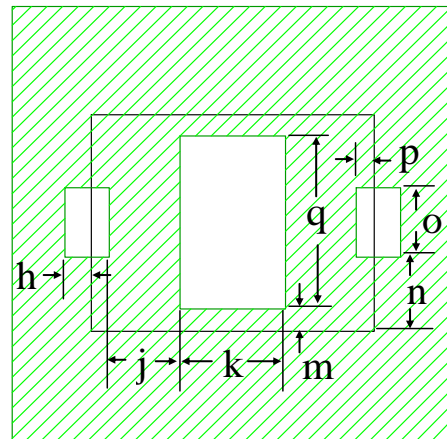

h	0.30 mm	n	0.85 mm
j	0.80 mm	o	0.80 mm
k	1.20 mm	p	0.20 mm
m	0.25 mm	q	2.00 mm

7. Packing method

7. 1 Taping conditions

Taping conditions are shown below. Refer to IEC60286-3

- (1) Tape must be wound clockwise with the feeding hole coming to the right hand side.
- (2) Top cover tape must not cover feeding holes of carrier tape and/or show out of carrier tape.
- (3) A blank section carrying no chips of a length of 160mm min. on ending section and 100mm min. on leading section must be provided.
- (4) A leading section of 400mm min. must be provided on top cover tape.

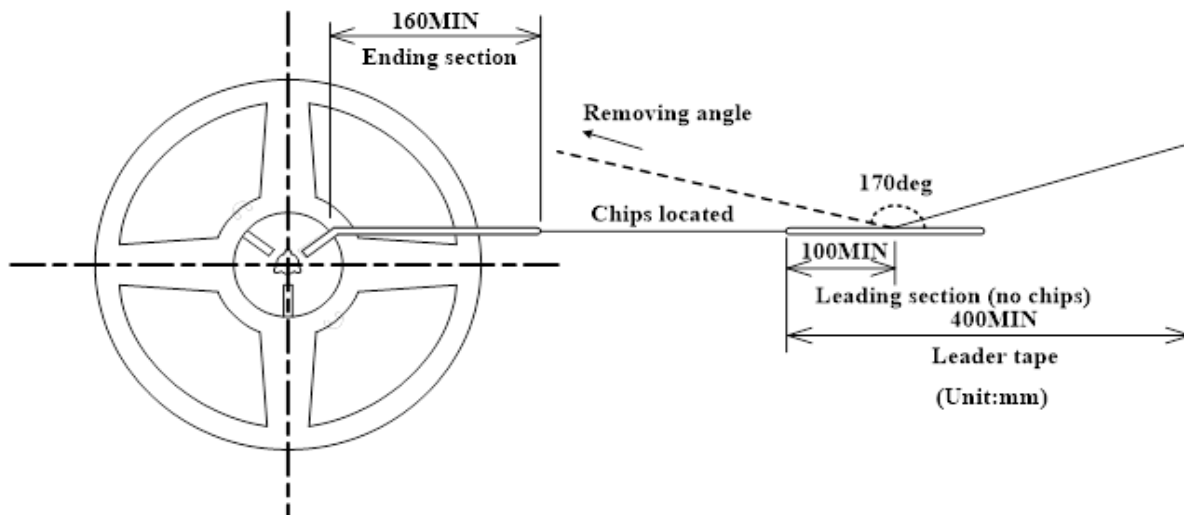

- (5) To end tape winding, the leading section of top cover tape must be stuck on a side of a reel with adhesive tape.
- (6) Removing force of top cover tape in the unwinding with an angle of 170 degrees between the removed side of a reel and carrier tape must be 0.1 to 1.0N.
- (7) When the embossed tape is turned upside down with the sealing tape peeled off, the filter body inside of the tape must fall off and the mounter must not cause a take-up mistake.
- (8) A sticker carrying Soshin product №, quantity, lot №, inspection date is to be placed on the specified side of reels. And Lot No. means our production control number. The shipment records are available if requested.

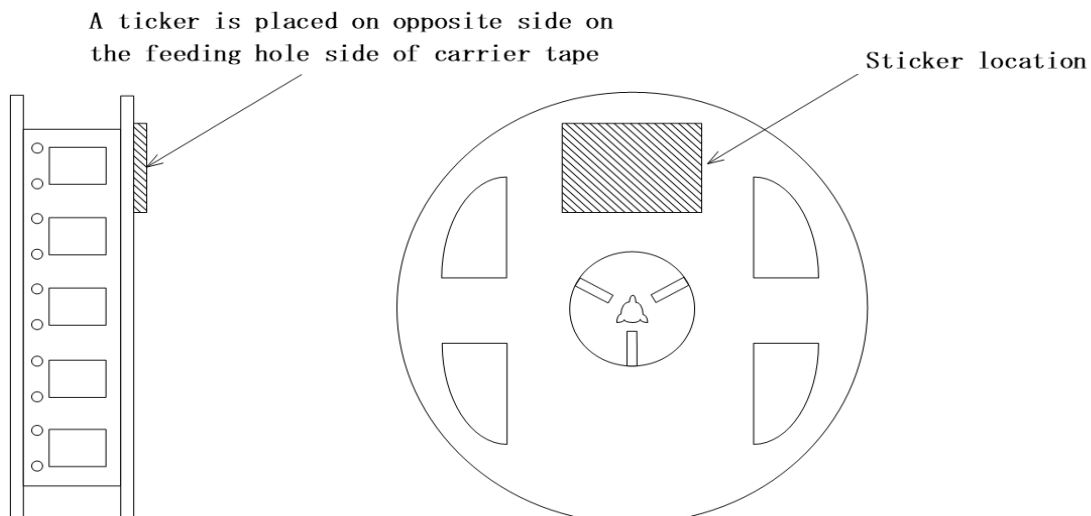

(9) Product orientation must be consistent. Products must not be positioned out of the mounting location.

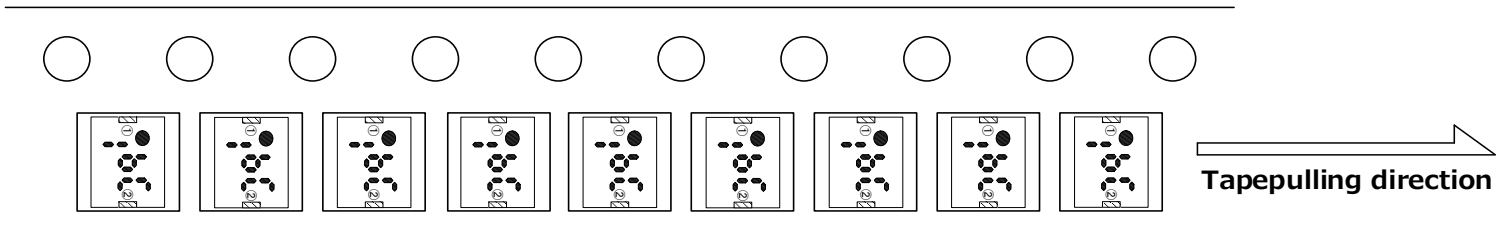

(10) A taping reel must be sealed in a plastic bag, individually.

(11) Tape-packaged quantity

The quantity is 2,000 pcs per single tape-package as a rule.

7. 2 Dimensions of the carrier tape (Unit : mm)

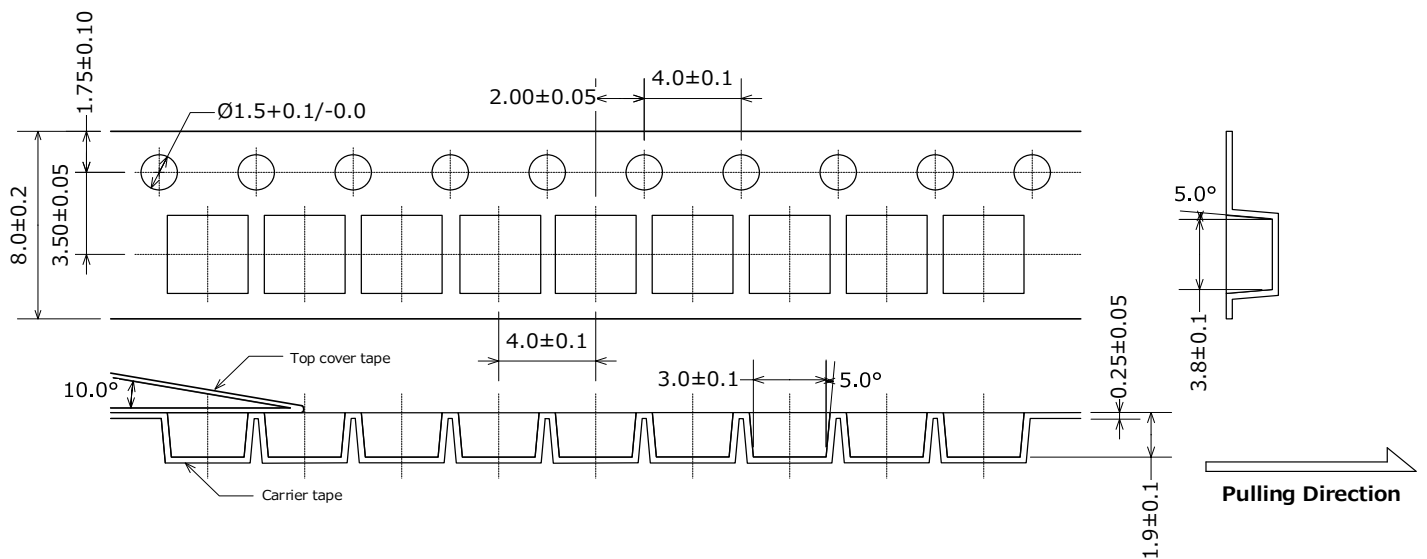

7. 3 Carrier tape reel dimensions (Unit : mm)

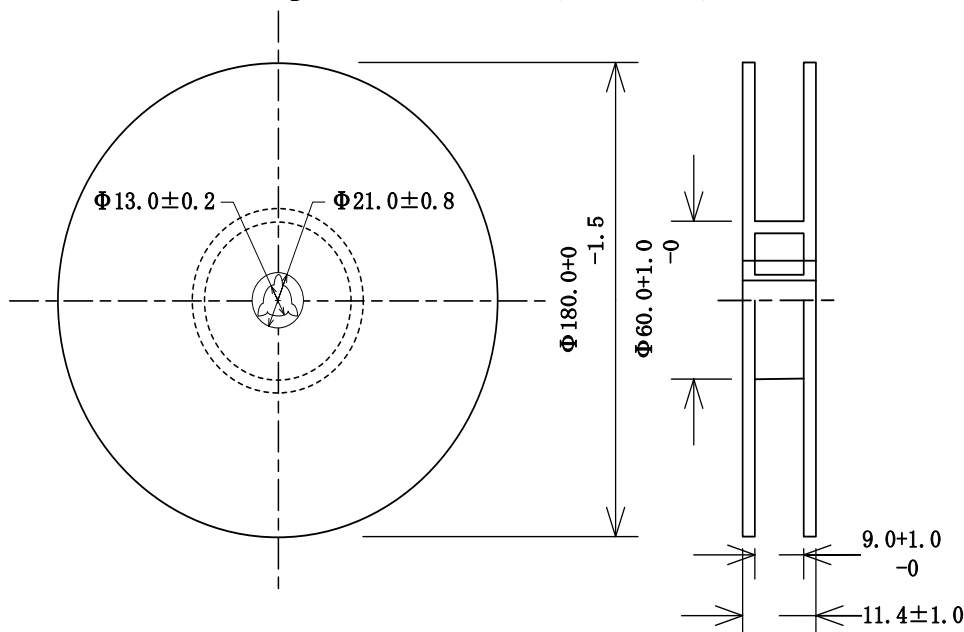

Material	
Cover tape	Polyester + LDPE + PSresin + Conductive coat
Carrier tape	PS+Carbon
Reel	PS