

NF3000C-VQ Series (RoHS认证产品)

三相三线式 480VAC

50-1000A大电流高衰减型



150A产品 外观



UL1283 (file No.E102708)

EN60939-2 (file No.R50031207)

用途

用于变频器电源、UPS以及各种产业机器的一次电源侧

规格

Part No.	Rated Current	Weight	Dimensions [mm]														
			A	B	C	D	E	F	G	H	J	K	L	M	N	P	
NF3050C-VQ	50A	2.9Kg	217	200	185	170	120	90	44	115	85	20	5.5x7	dia5.5	M6	M4	fig1
NF3060C-VQ	60A	3.0Kg	217	200	185	170	120	90	44	115	85	20	5.5x7	dia5.5	M6	M4	
NF3080C-VQ	80A	3.6Kg	217	200	185	170	120	90	44	115	85	20	5.5x7	dia5.5	M6	M4	
NF3100C-VQ	100A	4.3Kg	254	230	215	200	150	120	57	115	80	30	6.5x8	dia6.5	M8	M6	fig2
NF3150C-VQ	150A	9.0Kg	314	300	280	260	200	170	57	130	90	35	6.5x8	dia6.5	M8	M6	
NF3200C-VQ	200A	16Kg	450	430	338	100	190	230	7	180	133	M10	M8				
NF3250C-VQ	250A	16Kg	450	430	338	100	190	230	7	180	133	M10	M8				fig3
NF3300C-VQ	300A	23Kg	500	475	400		160	200	12	180	133	M10	M8				
NF3350C-VQ	350A	23Kg	500	475	400		160	200	12	180	133	M10	M8				fig4
NF3400C-VQ	400A	21Kg															
NF3500C-VQ	500A	21Kg															fig5
NF3600C-VQ	600A	26Kg															
NF3700C-VQ	700A	38Kg															fig6
NF3800C-VQ	800A	38Kg															
NF3900C-VQ	900A	60Kg															fig6
NF31000C-VQ	1000A	60Kg															
Rated Voltage	480VAC																
Leakage Current	250mA																
Ambient temp.	-20 up to 50 Deg.C																
Note:In case of center grounding type power supply and no phase disconnection, leakage current shall not flow. (As measured to UL1283/IEC)																	

fig. 1 (50-150A)

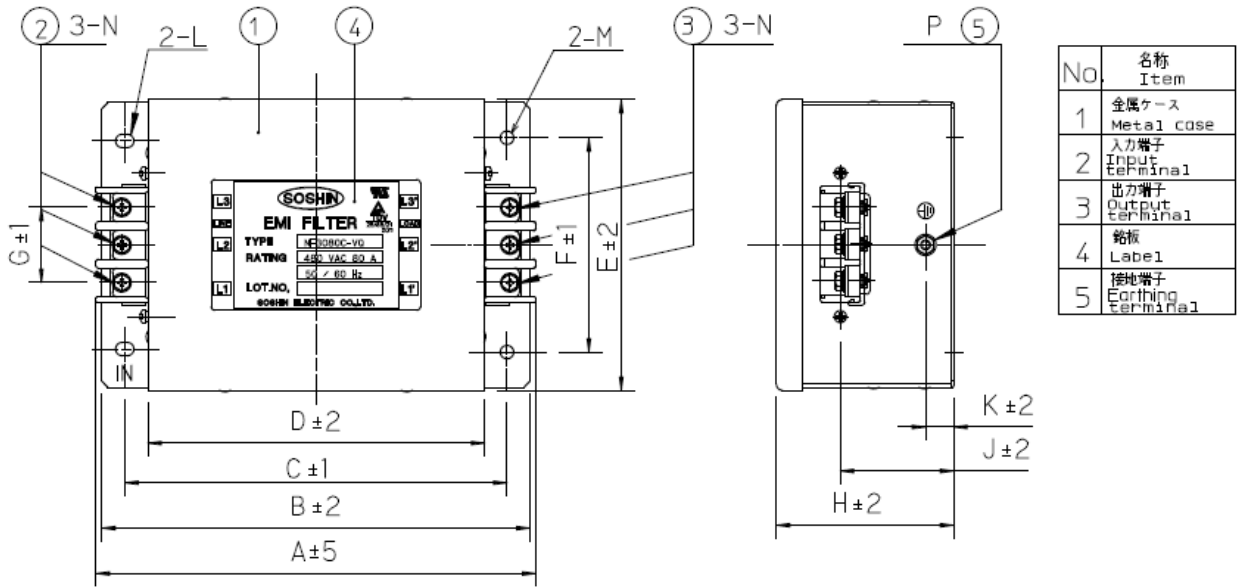

fig. 2 (200-350A)

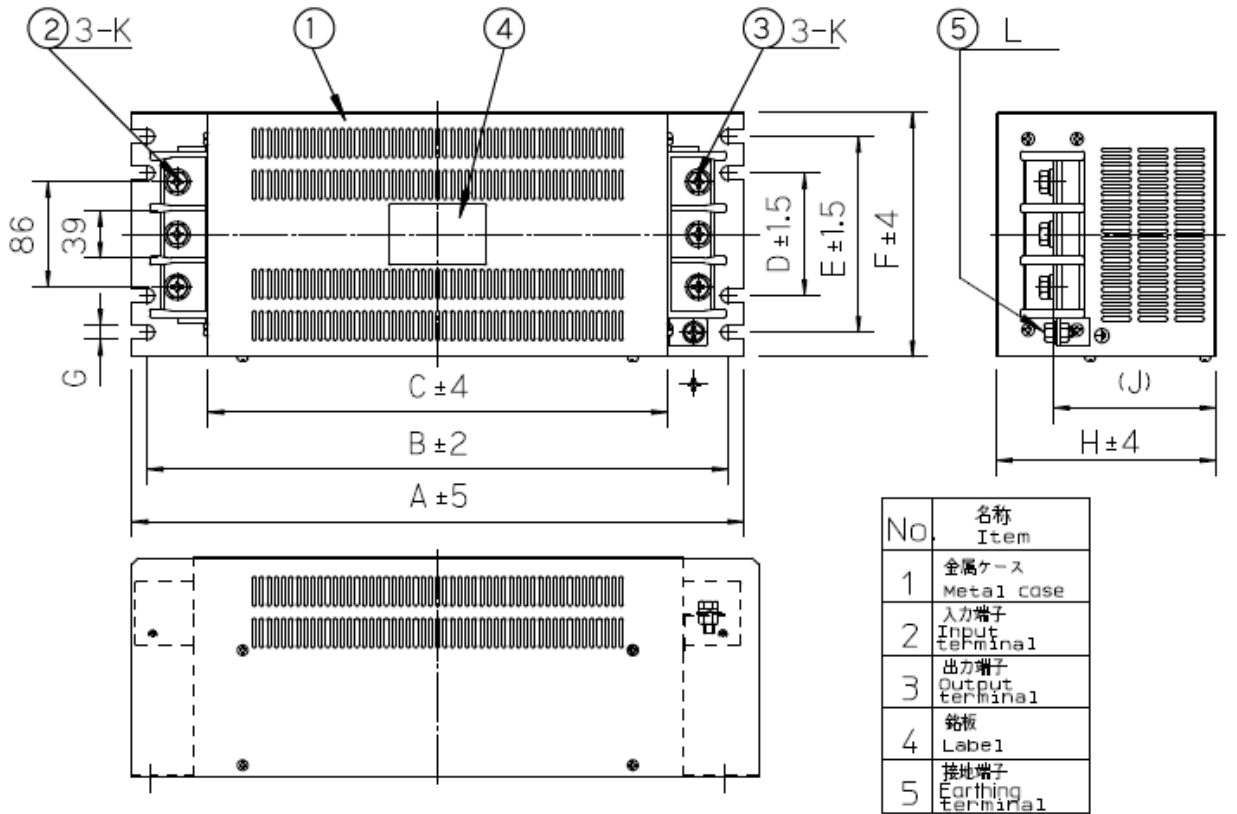
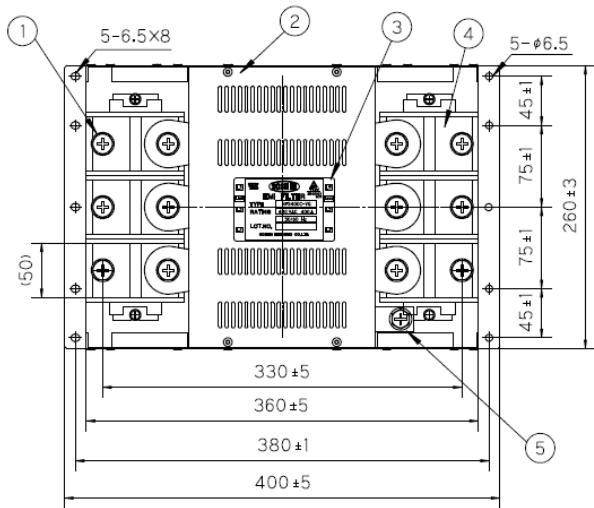

fig. 3 (400A)



No.	名称 Item	備考 Notes
1	入力端子 Input terminal	M12
2	金属ケース Metal case	
3	銘板 Label	
4	出力端子 Output terminal	M12
5	接地端子 Earthing terminal	M10

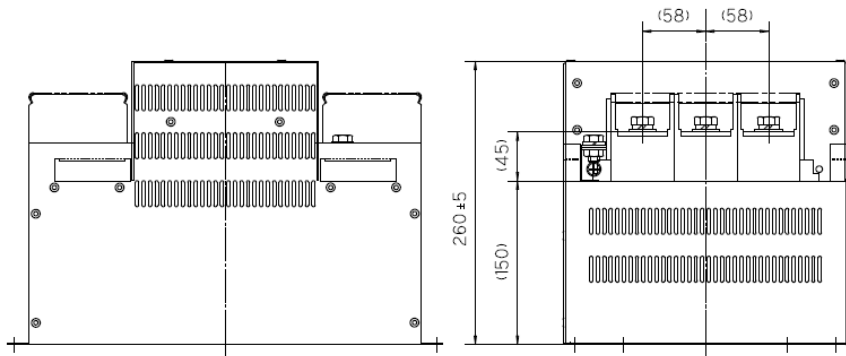
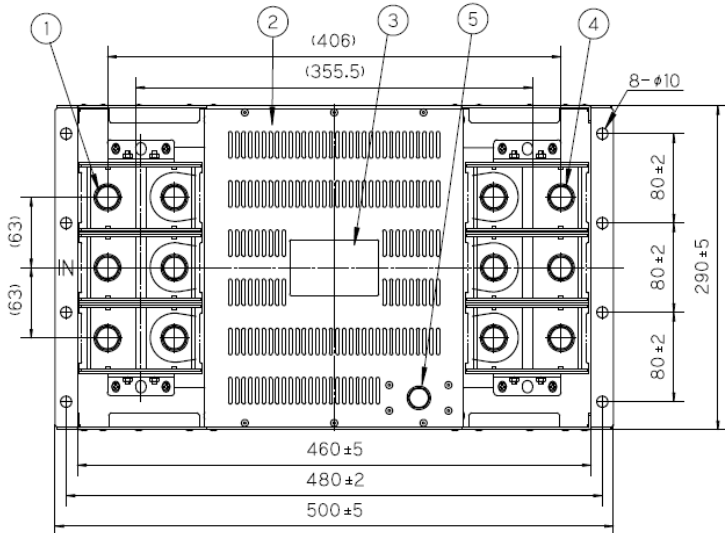

fig. 4 (500, 600A)



No.	名称 Item	規格 Standard
1	入力端子 Input terminal	M12
2	金属ケース Metal case	JIS
3	銘板 Label	
4	出力端子 Output terminal	M12
5	アース端子 Earthing terminal	M10

<<銘板表示例>>
<<Label>>

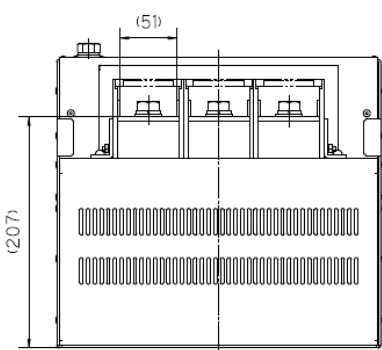
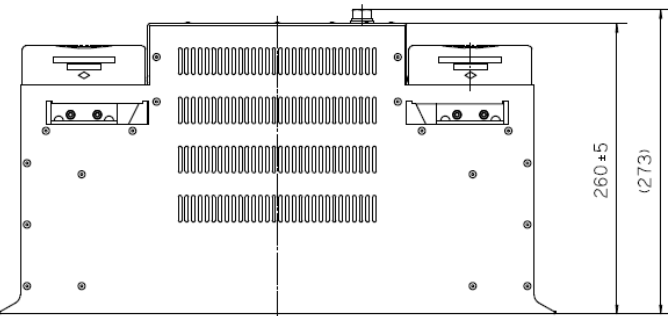
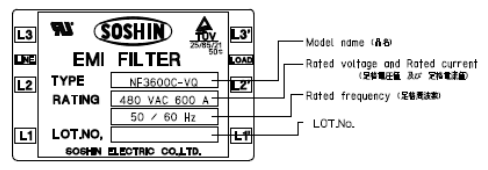

fig. 5 (700, 800A)

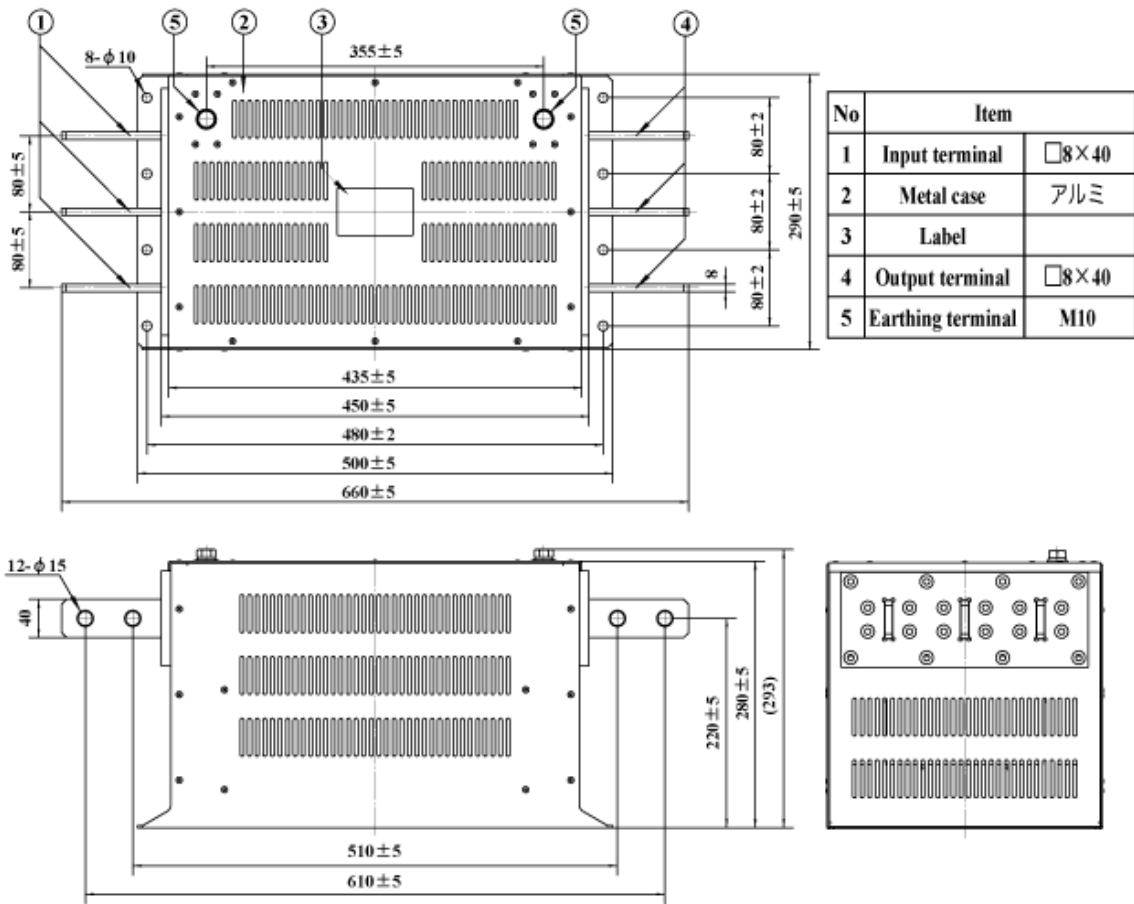
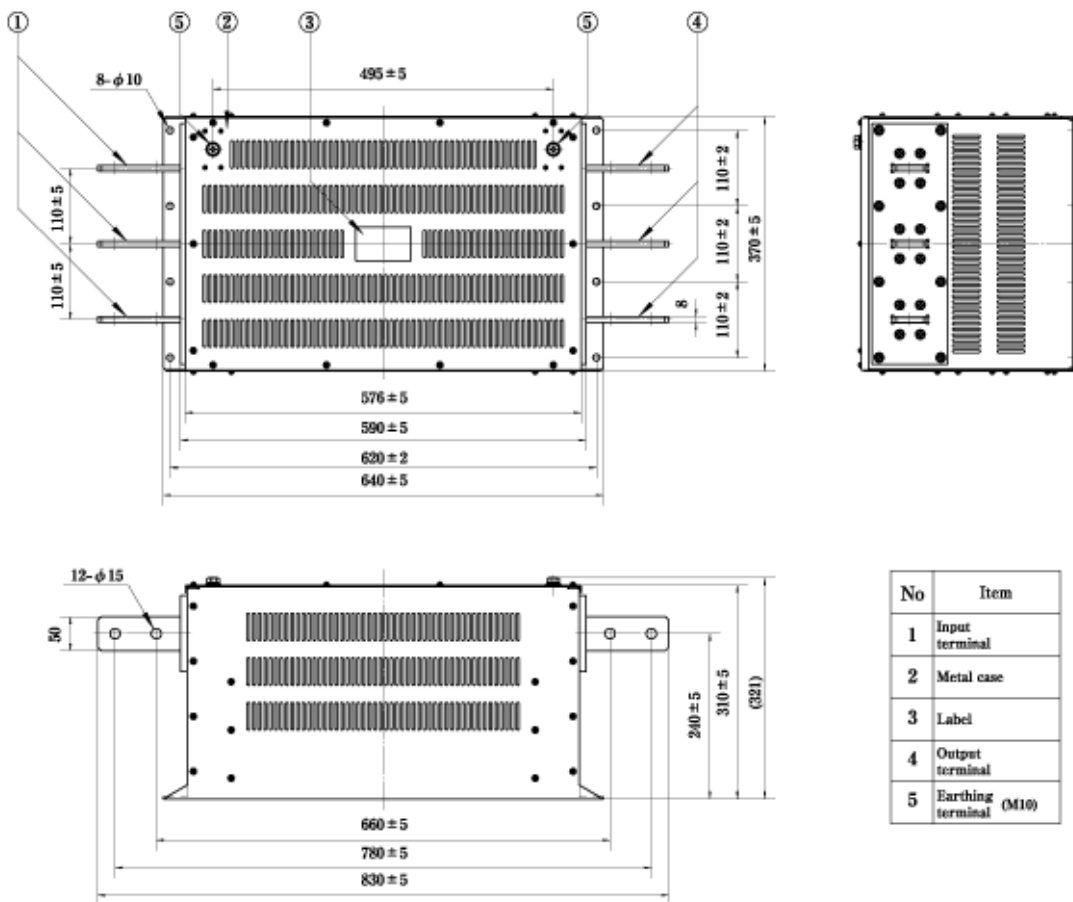
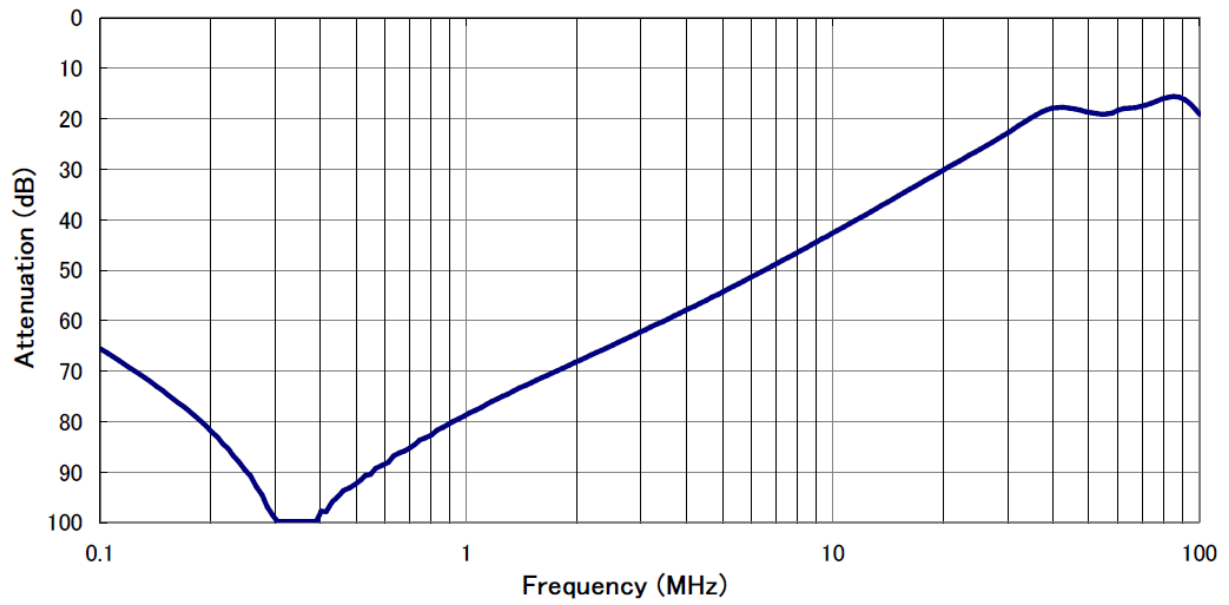

fig. 6 (900, 1000A)



代表特性 (50A)



代表特性 (200A)

